

# Measurement and Analysis Techniques of Formula One Chassis Development

Hideaki SHIBUE\*  
Akihiro IDA\*

Tomokazu SUZUKI\*  
Atsushi TSUBOUCHI\*

Mamoru URAKI\*  
Yasutaka KITAKI\*

## ABSTRACT

Measuring and analyzing chassis data are the basics of Formula One vehicle dynamics development. The acquired information is used in every stage of development, from design concept to race management. This paper explains examples of data analysis techniques including competitor performance analysis, dynamic performance indices used for chassis development and various techniques of measurement systems and sensors used in Formula One.

## 1. Introduction

The decisive difference of developing a Formula One car against a passenger car is that the engineers cannot drive and feel the cars themselves. Therefore, various high quality onboard data and analysis tools are needed to accurately understand the vehicle dynamics issues in order to improve car performances. Some of them are standardized to maximize tire performance during each run. These data are obtained through real-time processing using a telemetry system and being analyzed automatically so that the engineers can determine car setup for the next run whilst the car is still on the track. Simulating tools had been developed as well to predict and understand the phenomenon more in detail.

This paper introduces examples of the cutting edge measurement systems and sensors, competitor performance analysis technique including simulation tools and the latest analysis techniques of the dynamic performance indices.

## 2. Measurement Systems

### 2.1. Overview of Measurement Systems

The tasks of gathering data while running on a circuit track, analyzing that data, and implementing countermeasures form an important cycle in Formula One vehicle dynamics development. This cycle should be repeated accurately within a short time, so advanced measurement systems are built into Formula One chassis from the design stage. In this sense, a Formula One chassis could itself be considered a measurement apparatus. Even during races when performance is given

the highest priority, some 60 different types of sensors with close to 100 channels are mounted on the chassis. During tests when greater emphasis is placed on data acquisition, even more sensors are mounted with as many as 170 channels. In addition, video cameras and recorders are mounted to record moving images, and driver operations, racing lines, infrared images of tire temperatures, air flows, and other images are recorded in sync with the measurement data according to the application.

Figure 1 shows an overview of the measurement and analysis system. The sensor signals are first processed inside the onboard ECU and recorded in the data logger. In addition, some performance evaluation indices are also calculated inside the ECU in real time, and recorded together with the sensor data. Some of this data is sent by real-time telemetry to the pit, where it is processed instantly and continuously on a server (vTagServer:

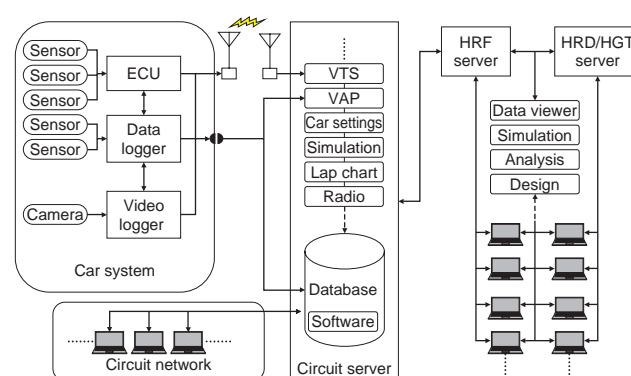

Fig. 1 Measurement and analysis system

\* Automobile R&D Center

VTS). Performance indicies are also calculated simultaneously at this time, enabling engineers to obtain analysis results and investigate the next setup changes before the car returns to the pit. This real-time data is distributed over a network, enabling simultaneous use not only in the pit, but by many members in the team factory and other locations with Internet connections.

When the car returns to the garage and the data downloading starts, the automatic data analysis system (VAP: Vehicle Analysis Package) transforms the data immediately to physical values within minutes. This data consists of approximately 2500 items that record the car status at sampling rates of up to 10 kHz, and the data volume can reach up to several GB per run. In addition to running data, virtually all information related to running is also managed centrally on the server. This information includes the lap times, setup information, driver comments and wireless audio for each car, weather and track condition information, work instructions and communication history between members, trouble information, and simulation analysis results.

The data is also transferred to the team factory (HRF) and Automobile R&D Center Tochigi (HGT) servers, enabling engineers in various fields to promote development while sharing data on the same information infrastructure, without the limitations of place or environment.

Including both races and running tests, Formula One running is performed for approximately 125 days per year (2008 results). Running data for up to 200 laps per day may be recorded, so measures to increase and maintain the accuracy and reliability of this enormous amount of measurement data are demanded. On the other hand, the chassis needs to be as slim, lightweight and have as low a center of gravity as possible, so the weight and space that can be used are limited. In addition, the engine that is rigidly connected to the chassis produces vibration over 3000 G, and the exhaust heat over 1000 °C. Therefore, efforts are made to develop original sensors and new measurement methods to support the needs of high accuracy, compact size, light weight, and high durability. Specific examples are introduced below.

## 2.2. Strain Gauged Wheel (SGW)

A six tire forces measuring wheel system (SGW) has been developed for Formula One excessive use. The requirements were to give accuracy of 1%, compact and easy to mount. This SGW uses a wireless system that is lighter weight and has less aerodynamic effect than the conventional wired system (Fig. 2). This reduced the aerodynamic effect of mounting, shortened the mounting preparation time, and enabled the acquisition of useful tire data with limited track testing (Fig. 3).

The force generated on the tire is measured using a strain sensor-type load cell configured by four pairs of bridge circuits (4 gauge method) built into the wheel. In addition, a measurement value processing box, a rotation angle calculation box, a battery box, and a transmitter box that wirelessly transmits the data to a matrix

calculation box (MCB) installed on the chassis, are mounted on the wheel disc surface. Matrix calculations and rotation angle and temperature compensation processing are performed inside the MCB on the data received by the chassis side to obtain six-component tire force data that is transmitted via CAN to the data logger on the chassis.

Loads of up to 30 kN and a bending moment of up to 4000 Nm can be measured under an operating environment with a maximum speed of 360 km/h and maximum temperature of 120 °C, which covers tire force measurement in the limit running state of a Formula One car. In particular, heat from around the brakes, which gets as hot as 700 °C or more, affects the temperature characteristics of electronic components including the strain sensors, and may result in a drop in measurement accuracy. Therefore, temperature compensation logic and a corresponding calibration method were established to address the issue of heat-induced changes in characteristics.

## 2.3. Tire Bulk Temperature Sensor (TBTS) and Tire Internal Surface Temperature Sensor (TIST)

Formula One tire performance is exercised by precisely controlling the temperature, load, slip, wear, and the like. Of these, the tire internal (structural portion) temperature is one of the most important control elements. Usually the tire surface temperatures are

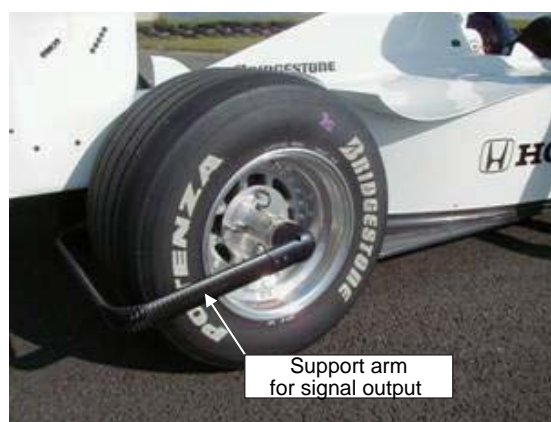

Fig. 2 Conventional SGW

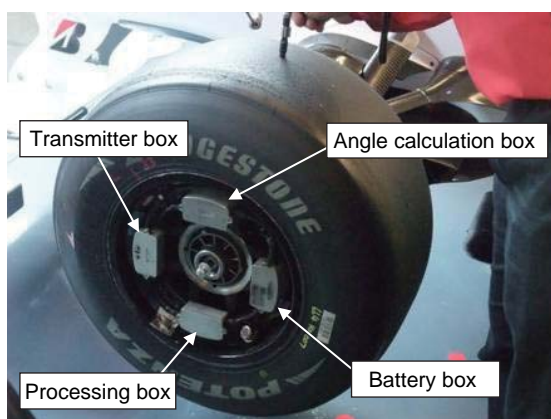

Fig. 3 Wireless SGW

measured during the run, and the internal bulk temperature inside the garage using probes. A hole can be made in part of the tread rubber and a thermometric element embedded to measure the temperature of passenger car and truck tires while running. However, Formula One tires have thin tread rubber just several mm thick, and the high loads and high-speed rotation make it a challenge to apply a similar method. Therefore, two types of sensors were developed: TBTS that embeds elements inside the tread rubber during tire manufacture (Fig. 4), and TIST that affixes elements to the tire internal surface (Fig. 5). A compact multi-channel telemetry system was also developed at the same time to acquire the data from the rotating tires, and this enabled measurement at racing speeds.

### 2.4. Multi-point Tire Temperature Sensor and Onboard Thermal Camera

To obtain continuous performance from Formula One tires, it is also important to maintain a proper pressure distribution within the tire contact patch. The load on the tire due to this pressure distribution can be estimated by measuring the tire surface temperature distribution during running, so infrared tire temperature sensors capable of simultaneously measuring multiple points were developed (Fig. 6). First, a 5-point sensor using multi-point thermopiles was developed to support grooved tires (5 ribs), and the number of points was then expanded to 8 and 16 points to increase the distribution

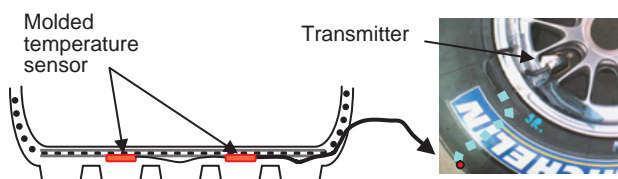

Fig. 4 Tire bulk temperature sensor (TBTS)

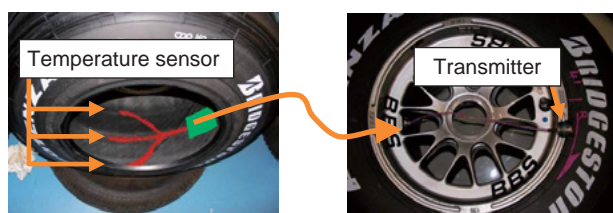

Fig. 5 Tire internal surface temperature sensor (TIST)

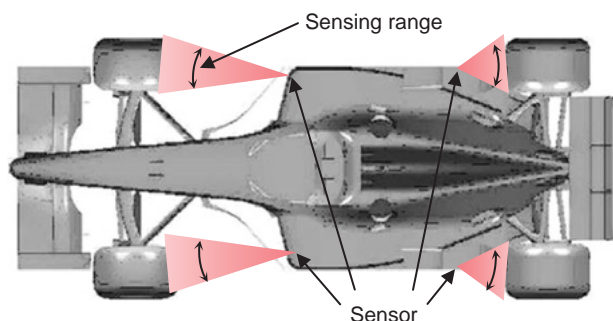

Fig. 6 Multiple tire surface temperature sensor

measurement resolution.

In parallel with this, a method that uses an onboard infrared camera to measure the tire surface temperature was also developed. A compact infrared camera was installed on the roll hoop where the video camera for TV broadcasts is normally mounted, and temperature images of all four tires were recorded using a four-sided mirror (Fig. 7). There is also the method of mounting multiple cameras aimed at each tire, but the mirror method has the merits of light weight, compact size, and high data quality due to recording all four tires at the same calibration. The recorded temperature images alone are useful information for evaluating the tire temperature distribution, but even more information can be extracted by analyzing the images using originally developed software, and converting into temperature distribution data.

### 2.5. Strain Gauged Suspension (SGS)

The strain gauged wheels that directly measures the force generated on the tires during running are useful in track tests that evaluate dynamic performance, but the increase in weight and the aerodynamic effects of the special wheel shape cannot be eliminated, so use is limited to tests. That is to say, a condition for the application of measuring systems to races is that there be no effect on vehicle dynamics if at all possible. Therefore, development of the SGS was promoted based on the concept of driving six tire forces from the loads on the suspension arms (Fig. 8).

A Formula One car suspension uses a double wishbone suspension type, but each arm is basically viewed as a

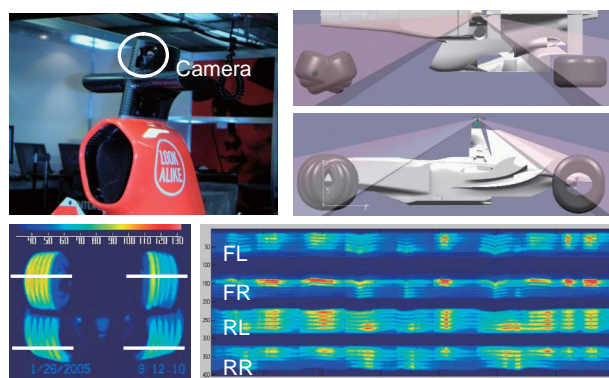

Fig. 7 Onboard thermal camera

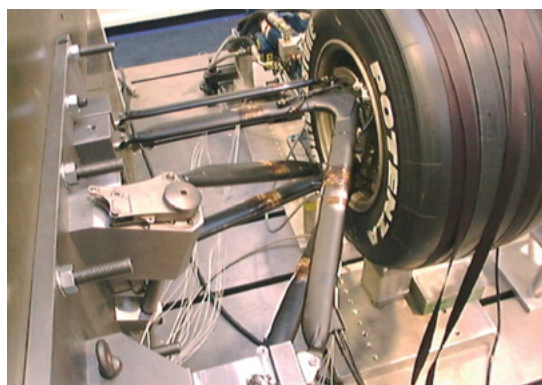

Fig. 8 Strain gauged suspension (SGS)

single straight link, and the six tire forces can be calculated from the combined force of each axle force including the push rod. That is to say, the six tire forces are obtained by performing finite element analysis and bench tests beforehand to derive the component force matrix that expresses the relationship between the six tire forces and the suspension arm axle forces, and then applying the inverse matrix of this component force matrix to the axle force measured during running. Realization of this system requires technologies that can handle A-shaped arms that are not straight links, take into account the bending stress due to the flexure joint, support changes in the component force matrix due to cornering and the suspension stroke, and take into account the effects of temperature, vibration, and other factors.

### 2.6. Wing Load Cells

The aerodynamic drag and lifts are usually calculated by using pushrod loads, but a direct wing load measurement system has been required to further understand the phenomenon around the wing elements itself. The requirements was to create a load cell that does not affect the aerodynamics, having ability to change wing elements without touching the load cell unit and off course strong enough to run on the circuit. A pillar type load cell (Fig. 9) was used for the front wings and a rear impact structure integrated load cell type (Fig. 10) on the rears.

### 2.7. Measurement Technology Using Test Rigs

In addition to track tests, bench tests are also often used in Formula One chassis development. Tests under stable environments with few undetermined elements enable the acquisition of detailed and precise information that cannot be obtained from track tests. In particular, the use of bench tests to obtain data that is a challenge to measure during running, such as the tire contact pressure distribution, helps to further deepen understanding of vehicle dynamics mechanisms.

The Contact Patch evaluation (CPE) system was developed as a bench test system that measures the tire

contact pressure distribution in the state with longitudinal and lateral forces acting on the tire. The sensor sheet is resistant to compression but weak in the shearing direction, so it was covered by a protective plate (0.1 mm thick SUS material), and then a non-slip sheet was affixed to the top of the protective plate (Fig. 11). Use of this system in combination with the Dynamic Vehicle Simulator (DVS) or other bench tester enables quantitative evaluation of the suspension dynamic characteristics and vehicle setup from the viewpoint of proper contact between the tire and the road surface (Fig. 12).

Figure 13 shows an example of analyzing the

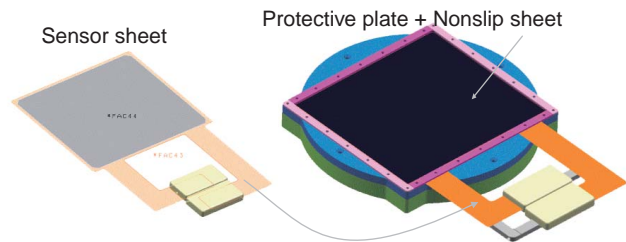

Fig. 11 CPE sensor

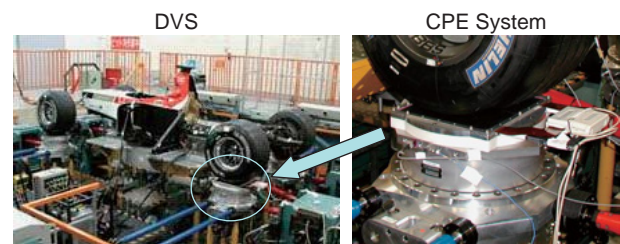

Fig. 12 CPE system on DVS

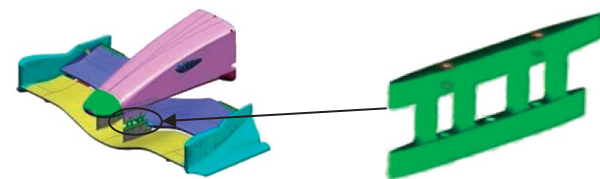
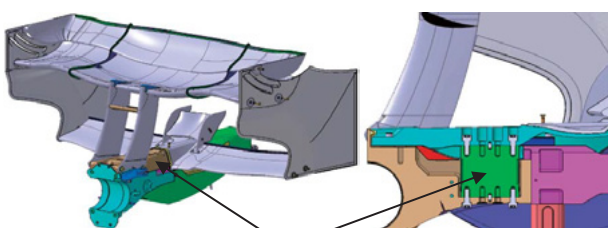

Fig. 9 Front wing load cell



Load cell

Fig. 10 Rear wing load cell

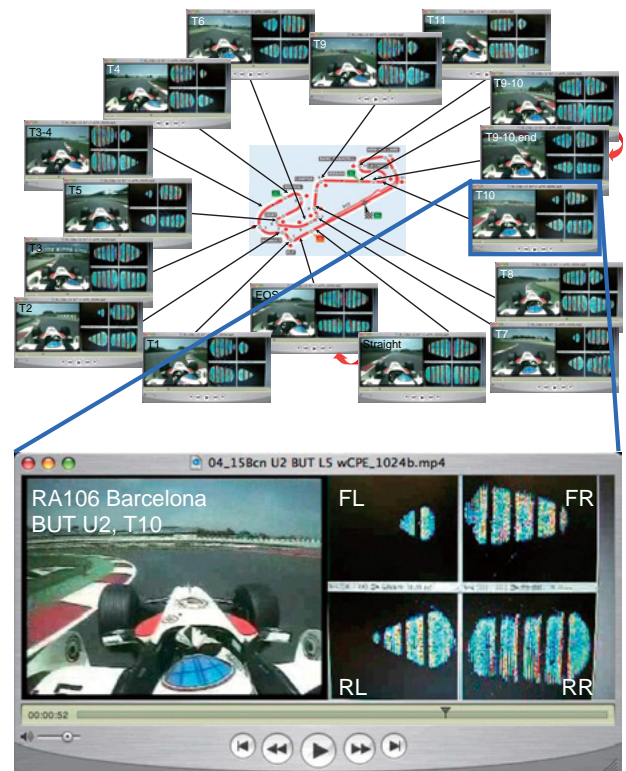

Fig. 13 Circuit simulation with CPE

constantly changing tire contact pressure distribution during running, simulated using the circuit simulation function of the DVS.

### 3. Competitor Performance Measurement and Analysis Technique

Understanding the primary factors for differences in lap times with competing cars during races is important for determining development directions. The ideal is to originally create the best in all technical areas, but in reality it is necessary to analyze the weak points of one's own car and formulate countermeasure policies to make efficient use of limited time and resources. Unlike production car development, it is unlikely that competing cars can be obtained for direct comparison and analysis, so original technology was developed to determine and analyze the primary factors for differences in performance without actually touching competing cars.

#### 3.1. Acoustic Analysis

Regulation changes in 2008 added a maximum engine speed limit of 19000 rpm, but prior to that it was important to know the engine speed of competing cars as a guideline for estimating the maximum power output. During TV broadcasts of races, sound is broadcast simultaneously with the image from onboard cameras, and the engine speed can be accurately known from the frequency of the engine noise. At test tracks without TV broadcasting, the sound is recorded and speed measured simultaneously using a PC, microphone and speed gun, and the engine speed is calculated from the engine sound by compensating for the Doppler effect. This data can then be further processed to estimate the vehicle speed diagram, gear ratio, and other information (Fig. 14).

#### 3.2. Infrared Thermal Images

The load on the tires differs for each car due to differences in the weight distribution, height of the center of gravity, suspension geometry, setup, aerodynamic characteristics, driving style, and other factors, and results in differences in the tire surface temperature distribution. Differences in the characteristics of each car can be estimated by installing thermal cameras on the course side, imaging the tire surface temperatures of each car during running, and comparing the differences in the temperature distributions (Fig. 15).

#### 3.3. Image Analysis

Various analyses can be made based on TV broadcast

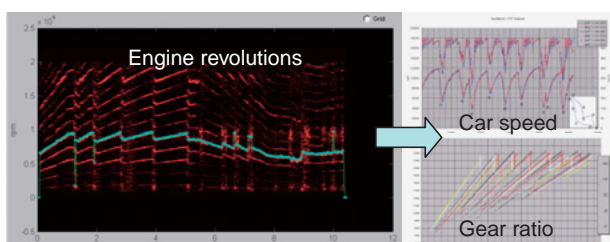

Fig. 14 Acoustic analysis

images and images filmed by digital cameras or other means. The tire contact camber angle and the chassis roll angle can be estimated from images that filmed cornering (Fig. 16). Analysis of this information together with the abovementioned thermography temperature data enables an understanding of differences in the chassis characteristics, suspension characteristics, and tire load conditions.

Overlaying the running images of multiple cars filmed during circuit running enables analysis of differences in vehicle speeds, braking points, racing lines, handling characteristics and other information (Fig. 17). In addition, minute time differences over the filmed section can be calculated from these images. Time differences over the entire course can also be calculated from the onboard camera images of TV broadcasts.

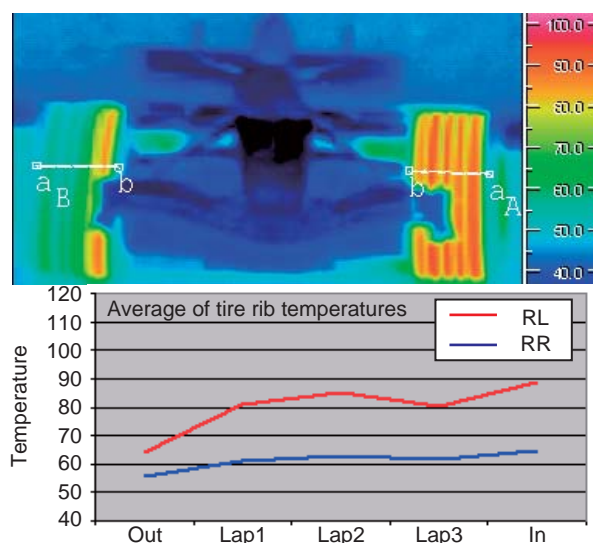

Fig. 15 Infrared thermal image

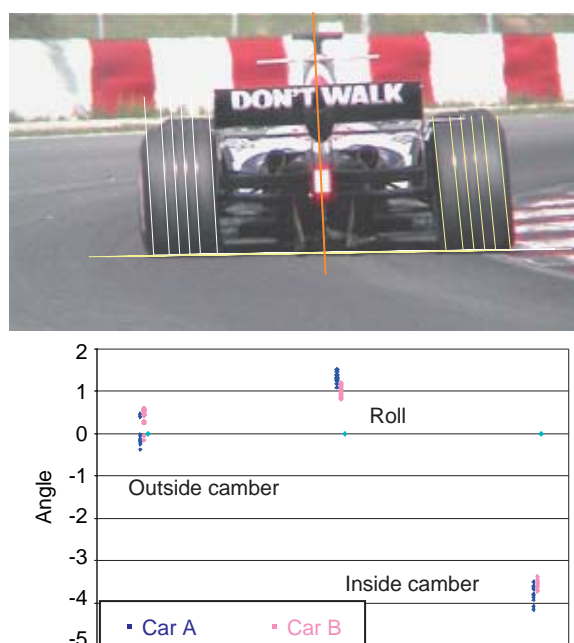

Fig. 16 Image analysis

### 3.4. High Speed Video Image Analysis

Various pieces of information can be obtained by using high-speed cameras that have a faster shutter speed and a higher frame rate than normal video cameras. The slip ratio (traction control performance) of the driving wheels during acceleration can be calculated from the difference in the rotation angles of the front and rear tires, and the tire surface wear conditions can also be observed (Fig. 18).

### 3.5. Three-dimensional Modeling

Three-dimensional models are created using multiple photos to understand the aerodynamic components, the suspension geometry and other items (Fig. 19). Comparing these models on the CAD system enables us to help validate the competitor performances.



Fig. 17 Image overlay processing

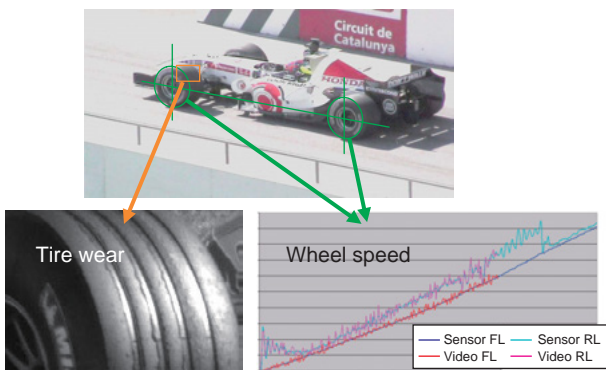

Fig. 18 High speed video analysis



Fig. 19 Modeling in three dimensions

## 4. Measurement Data Analysis Systems

Aerodynamic characteristics (down force and drag) and the three-component force (wheel load, longitudinal force, lateral force) acting on the tires during running are important information for analyzing Formula One dynamics. This information is used to determine the policies for aerodynamic development and tire management and the vehicle setup. However, it is a challenge to directly measure these forces, so it is required to perform high level estimation using a combination of various sensor data, suspension characteristic information obtained from rig tests and needless to say about the vehicle dynamics understanding.

During races and track tests, well over 100 different pieces of chassis performance data are required for analysis, which makes development of a system that automatically calculates vast amounts of chassis performance data vital to enable swift analysis. Therefore, an automatic analyzing system called the Vehicle Analysis Package (VAP) was developed to support performance analysis. This system used the onboard data and the suspension model information and more to say it allowed real time analysis using the telemetry system.

### 4.1. Overview of VAP System

The VAP system is introduced below using the example of calculating the down force, which is a main analysis item. Thus far limitations on down force calculations meant that evaluation of aerodynamic performance during running had been possible only under the limited conditions of mode running at a constant vehicle speed on a straight track. In contrast, dozens of sensor values and complex models need be used to enable calculations over all ranges, including braking, driving and turning, while running at racing speeds. Figure 20 shows an overview of the down force calculation model. Here, the down force is derived from the calculation results for the two main divisions of the wheel load and the inertia force.

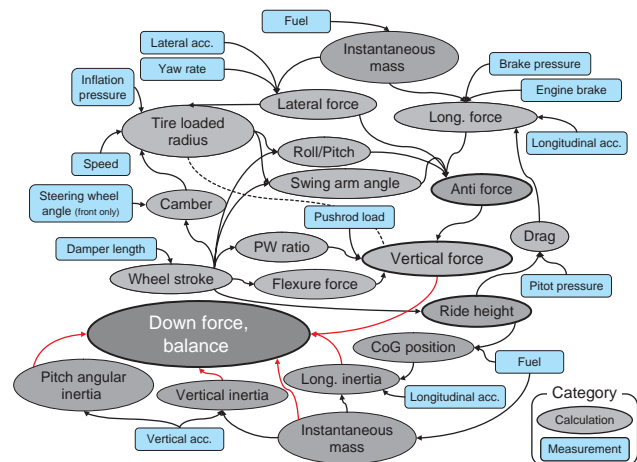

Fig. 20 Overview of down force calculation in VAP

The wheel load comprises the load on the pushrod, which bears the main load, the flexure force due to the bend arm, and the jack-up force due to the suspension geometry. Calculation of the jack-up force in particular also takes into account the suspension stroke, tire deflection, and other factors, so the wheel load is calculated using a combination of over 20 different sensor values and suspension and tire characteristics models.

The calculation of inertial force is needed in order to calculate the load transfer amount due to braking, driving and turning, and to eliminate variation in the wheel load, which is due to vertical centrifugal force resulting from the vertical bending radius of the circuit course, from the down force calculations. This means that the acceleration calculation accuracy is important, and requires accurate calculation of the pitch and roll angles and the height of the center of gravity.

The calculation accuracy is verified using a wind tunnel and bench testers such as the DVS (Fig. 21).

Figure 22 shows the results of accuracy verification using the DVS. Here, circuit simulations were performed using running data, and the VAP calculation results were compared with the down force applied as a load from the DVS. The results show a close match for both the front and rear wheels.

#### 4.2. Introduction of Data Analysis Systems that Support Telemetry

Regulation changes implemented by the FIA from 2008 onward mandated the introduction of a common ECU made by McLaren Electronic Systems (MES). One of the functions of this ECU is a telemetry data analysis system (vTagServer: VTS).

The main function of telemetry systems thus far had been to transmit the information from onboard sensors to the pit, and the main role for this had been to monitor trouble occurring in the chassis while running. In contrast, one of the functions strongly desired from the

standpoint of vehicle dynamics development was real-time analysis of dynamic performance while running. At circuits it is necessary to analyze running data, determine the next setup, and determine which running modes need to be added, all within the limited time after the vehicle returns to the pit until the next run. Therefore, real-time analysis was strongly desired by engineers engaged in vehicle dynamics development.

With the introduction of this new telemetry system, the logic of the automatic data analysis system was transplanted to the Simulink model, which achieved real-time data analysis by processing data on the VTS. In addition, the VTS can also be used as a post processing system, and development of an integrated system is proceeding with the aim of realizing a seamless environment from real-time analysis to more detailed analysis (Fig. 23).

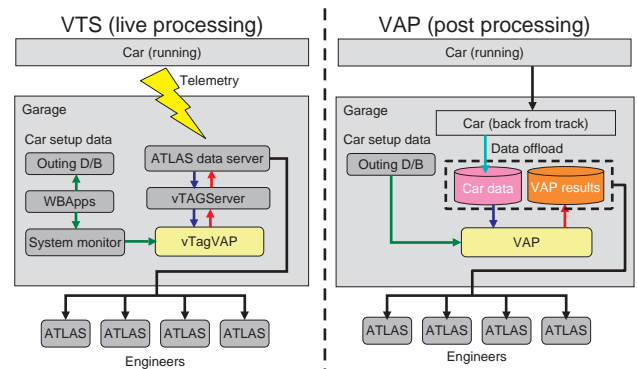

Fig. 23 Overview of live and post processing system

### 5. Creation of Vehicle Dynamics Indices

To evaluate the analysis data as an expression for vehicle dynamics, and to use those results for vehicle design and setup at circuits, the ability to extract physical quantities that represent performance and to discuss these quantitatively and simply is required. That is to say, dynamic performance indices are important.

Without dynamic performance indices, it is a challenge to quantitatively compare multiple setups in a short time at circuits, where speed is required, and such work cannot help but rely on driver comments and the experience of the engineers. This also makes quantitative investigation a challenge in the area of vehicle design, such as when discussing vehicle dynamics targets or tradeoffs between various design elements.

#### 5.1. Development of Braking Stability Indices

Vehicles with good braking stability not only enable shorter lap times by delaying braking, but also increase the chances of overtaking using braking. For these reasons, braking stability is one of the most important dynamic performance in Formula One. However, while it is discussed as the driver's sense of "confidence in the car while braking," there was no index that expressed the braking stability in a quantitative manner. Therefore,

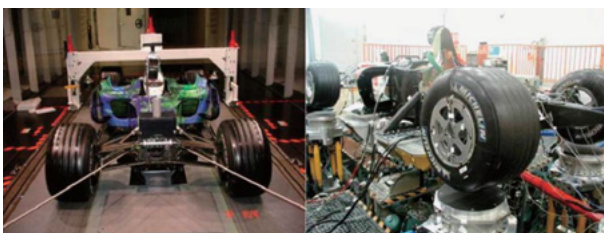

Fig. 21 Correlation test with wind tunnel and DVS

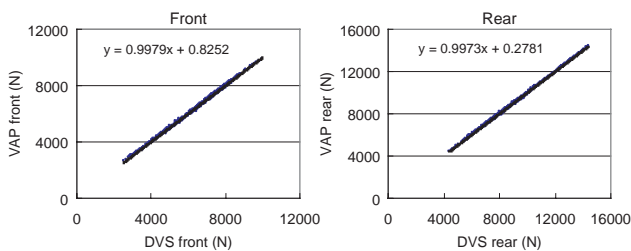

Fig. 22 Correlation test on DVS

braking stability indices were developed as an index of dynamic performance.

### 5.2. Candidates for Braking Stability Indices

Ten different physical quantities thought to potentially express braking stability were hypothesized as index candidates, and each candidate was verified to determine whether it was suitable as an index. The typical index physical quantity candidates are described below (Fig. 24).

(1) Stabilizing yaw moment margin (MM)

The body slip angle was imaginarily increased from the current car state, and the driver was hypothesized to feel confidence according to the difference (margin) from the maximum value of the calculated stabilizing yaw moment.

(2) Stabilizing yaw moment variation rate (dM/ds)

The degree of sensitivity relative to the body slip angle of the stabilizing yaw moment in the current car state was hypothesized to affect confidence.

(3) Lower envelope of vertical load on rear outer wheel (Fz)

It was hypothesized that the tire gripping force is unable to track high frequency fluctuations in the wheel load, with the result that only force equivalent to the lower envelope of the wheel load can be exercised.

### 5.3. Verification of Indices

The premise was that “cars with higher braking stability enable stronger, more stable braking, with the result that section times should be enhanced.” Running was performed using various proposed setups thought to provide different stability, the correlations between each physical quantity over the braking section and the section time were analyzed, and the physical quantities with a correlation coefficient of 0.7 or more, which indicates a strong correlation, were extracted from the results. In addition, the braking sections were divided into straight braking sections and turn braking sections, and the correlations were analyzed for each section.

The relationship between the two factors may be nonlinear, so a non-parametric analysis method called Spearman’s rank correlation coefficient was used. In addition, a “no correlation” null hypothesis to be rejected was established, and hypothesis testing was performed using a 5% standard to examine whether the calculated correlation coefficients are significant. The correlation coefficient value that could be obtained only at a 5% probability when there was no correlation between the

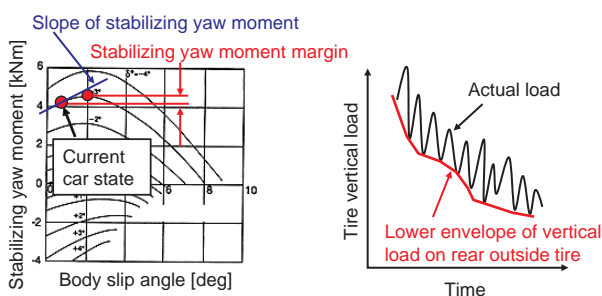

Fig. 24 Candidates for braking stability indices

two factors was calculated, and when a correlation coefficient that exceeded this value was calculated, the null hypothesis was rejected and the factors were judged to have a significant correlation (Fig. 25).

### 5.4. Test Methods and Verification Results

Proposed setups with different transitions in the center of down force (CoP) during braking were set. Running tests were conducted on two different circuit tracks to compare a baseline setup (the CoP shifts to the front from the beginning of braking towards the corner apex point) with other setups changed so that the CoP shifts towards the rear, which was presumed to enhance braking stability (Fig. 26).

Figure 27 shows the correlation coefficient analysis results for straight braking sections. Of all the

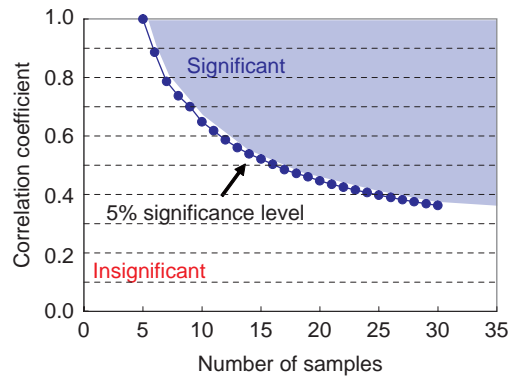

Fig. 25 Significance test for Spearman's rank correlation coefficient

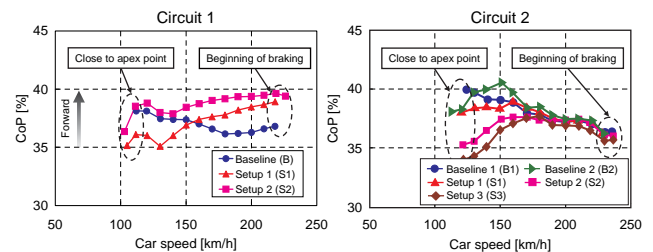

Fig. 26 Setups with different CoP transition in braking

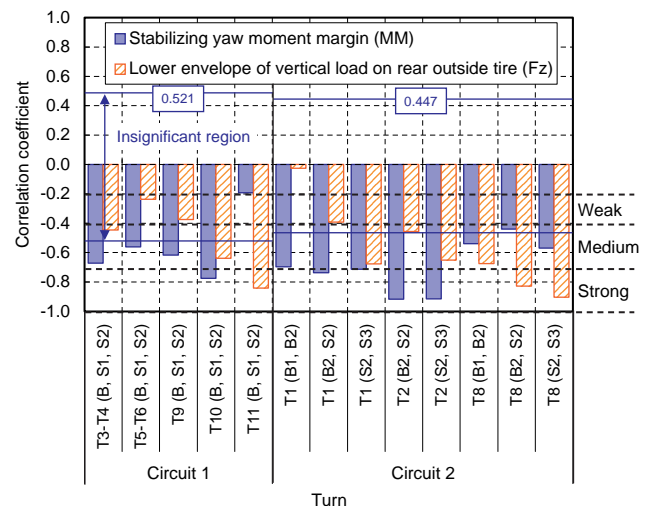

Fig. 27 Correlation analysis in straight braking



candidates, this figure shows the results of only MM and Fz, which exhibited stably high correlations. Of the MM data suitable for analysis, 80.0% of Circuit 1 samples exhibited a significant correlation, and 20.0% showed a strong correlation. For Circuit 2 these figures were 87.5% and 50.0%, respectively. This exceeded the Fz results for Circuit 1 (40.0% significant correlation, 20.0% strong correlation) and Circuit 2 (75% significant correlation, 25% strong correlation), indicating that MM is more suitable as an index in straight braking sections.

In turn braking sections, MM and dM/ds exhibited higher correlations compared to other candidates (Fig. 28). However, these correlations were not as stably high as that of MM in straight braking sections. Here, 33.3% of MM samples for Circuit 1 showed a significant correlation (33.3% strong correlation), and 66.6% (0.00%) for Circuit 2. The respective results for dM/ds were 66.6% (33.3%) for Circuit 1, and 25.0% (8.33%) for Circuit 2.

### 5.5. Summary of Index Creation

It is necessary to create dynamic performance indices in order to scientifically and quantitatively discuss vehicle design and setup without being dependent on engineer experience and driver senses. Indices were created for braking stability, which is one of the many items that comprises dynamic performance, and knowledge was gained regarding physical quantities that can serve as indices. Indices need also be created successively for other vehicle dynamics items.

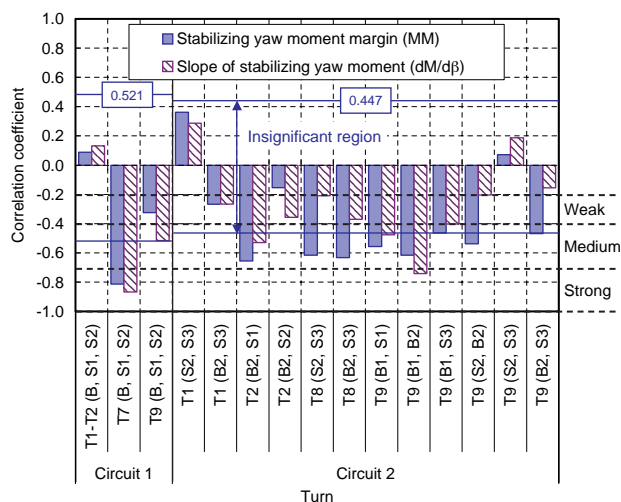

Fig. 28 Correlation analysis in turn-in braking

conditions such as vibration heat and speed are so severe that a very high task is required. These techniques obtained in this project will be useful in passenger car development as well.

### Acknowledgements

The authors wish to express their deep thanks to related parties at Tokyo Sokki Kenkyujo Co., Ltd., for their cooperation in developing the Strain Gauged Wheel, Kyowa Electronic Instruments Co., Ltd., for their cooperation in developing the wing load cells, TUV SUD Automotive GmbH for their cooperation in developing tire temperature sensors, and Bridgestone Corporation for their cooperation in developing vehicle dynamics indices.

### Author



Hideaki SHIBUE

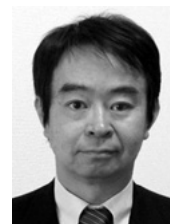

Tomokazu SUZUKI



Mamoru URAKI



Akihiro IDA



Atsushi TSUBOUCHI



Yasutaka KITAKI

## 6. Conclusion

On a qualifying session, the lap time differences between the top teams are usually in within 0.1 s. Assuming a lap time of 100 s, this could be called a competition over differences in performance of approximately 0.1%. Therefore, the demand to have the cutting edge technology for both measurements and analysis is very high. In Formula One, the environmental